

Mobius® FlexReady Solution with Smart Flexware® Assemblies for TFF

For Purification of Clinical and
Process Scale Biologics

The Mobius® FlexReady Solution with Smart Flexware® Assemblies is designed to achieve separation and purification of mAbs, vaccines, plasma, and therapeutic proteins.

The Mobius® FlexReady Solution with Smart Flexware® Assemblies delivers optimal operational flexibility in a very simple and fast way. Thanks to our innovative single-use flowpath assemblies that enable closed processing, contamination risks are reduced, giving you the confidence you need to tackle any TFF challenge.



Features & Benefits

- **Flexibility**—Standard hardware platform supports multi-product and multi-scale production, maximizing the flexibility of high-value investments
- **100% single-use flowpath**—Smart Flexware® single-use assemblies provide ease-of-use, robust reproducibility, and elimination of carryover from previous batches
- **Closed mode of operation** is possible with specifically designed flowpath and equipment, allowing to reduce contamination risk while increasing flexibility and efficiency
- **Fully automated**—Enables you to easily and consistently produce clinical- and preclinical-scale quantities of high-value drug products
- **User-friendly**—The system shares common elements, such as software, design, and maintenance components with our other systems, making training and validation easier across scales and applications
- **Services**—Comprehensive services ensure rapid implementation and optimized performance
- Supports **industry-leading devices**, including Pellicon® cassettes and Pellicon® capsules

System Hardware

The Mobius® FlexReady Solution with Smart Flexware® assemblies covers multiple applications, allowing production facilities to maximize the return on their investment. The P&IDs shown in Figures 1 and 2 feature the two flowpath configurations.

System's P&ID

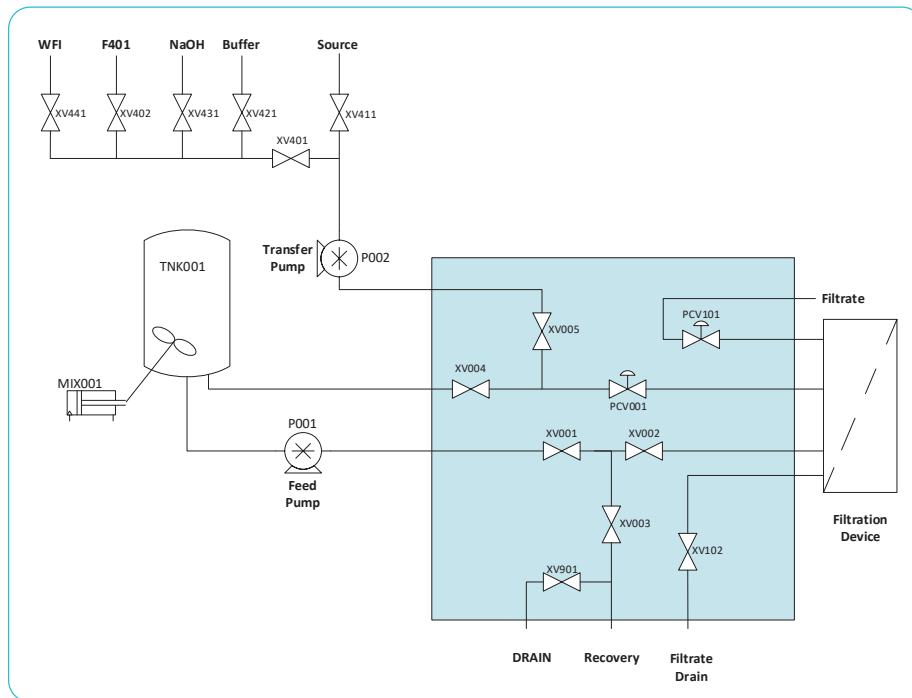

Figure 1: Simplified P&ID for TF2S used with single-use flowpath with CPC® MPC and TC connections

Connections and disconnections occur during certain steps of the TFF operation (flushing, cleaning, draining, etc.).

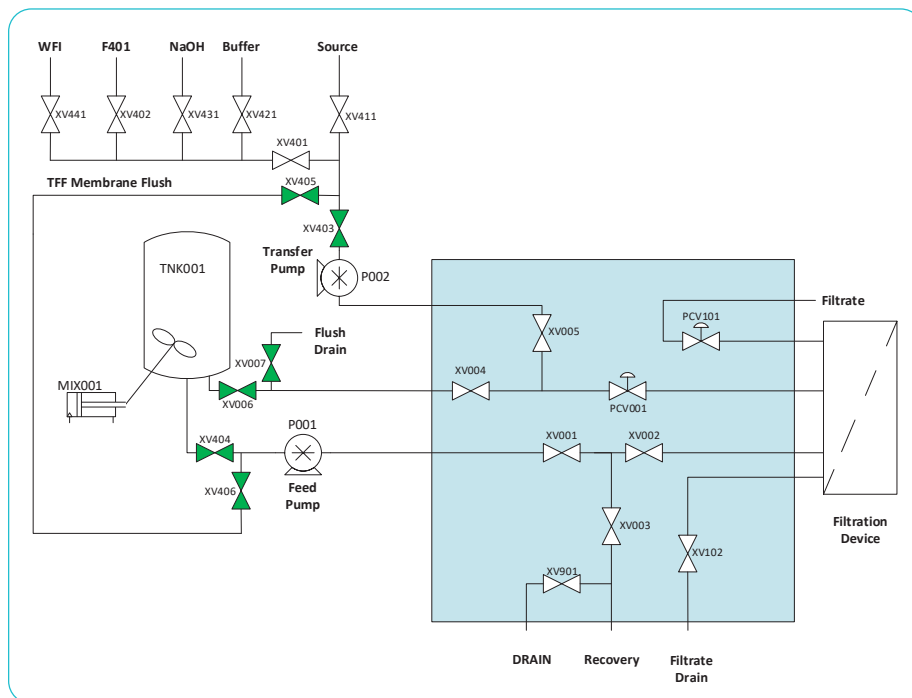

Figure 2: Simplified P&ID for TF2S system used with single-use flowpath enabling closed processing with CPC® AseptiQuik® connectors

Once the flowpath is installed using aseptic connectors, all TFF operations can be performed without the need to connect/disconnect.

Control of fluid flow during flushing and draining is done with pneumatic pinch clamps.

Sensor Instrumentation

Our system gives you the option to choose single- or multi-use sensors for TFF filtrate, without having to sacrifice performance in favor of reducing cleaning or risk of carryover. The hardware for receiving and transmitting data is the same regardless of single- or multi-use approach, increasing the flexibility of your facility, balancing economy and scale-up effort.

Smart Flexware® Assemblies

Smart Flexware® single-use assemblies are delivering equivalent performance to that of traditional stainless-steel systems, while maximizing system flexibility. These assemblies are clearly labeled, significantly reducing the risk of operator error and the challenges typically associated with installing single-use flowpaths. The system and flowpath are designed to minimize dead space and to optimize TFF processes through state of the art design of tank. In addition, we offer a flowpath designed to enable closed processing, allowing you to reduce cleanroom requirements and increase operator safety.

Benefits

- Gamma irradiated and ready to use, reducing set-up time
- Fewer connections versus traditional single-use, reducing risk of integrity failure
- Reduced dead legs maximize product purity, product recovery, and diafiltration efficiency
- No cleaning validation required
- Closed mode of operation allows to reduce contamination risks while increasing manufacturing efficiency and flexibility, when paired with Pellicon® capsule

Tangential Flow Filtration (TFF) Configuration

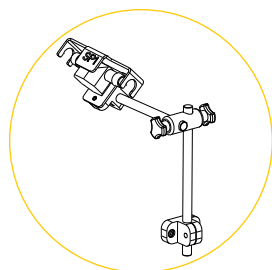

Sampling support
for non-closed flowpath

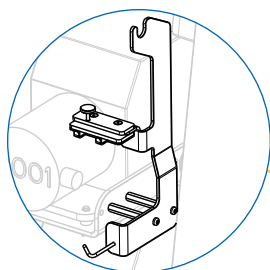

Sampling support for closed
flowpath assemblies using
NovaSeptum® sterile
sampling system

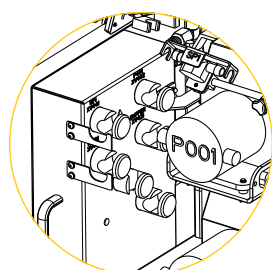

Pump cart and transfer
manifold controlling
5 inlets on transfer line

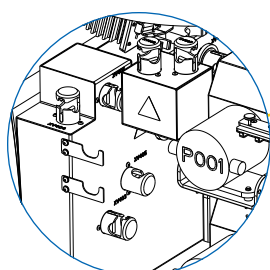

Pump cart for closed
processing, with 6
additional valves to
allow run without
connection/ disconnection

Feed/recycle mixing tank

Feed Pump
Low shear diaphragm pump

Transfer Pump
Low shear diaphragm pump

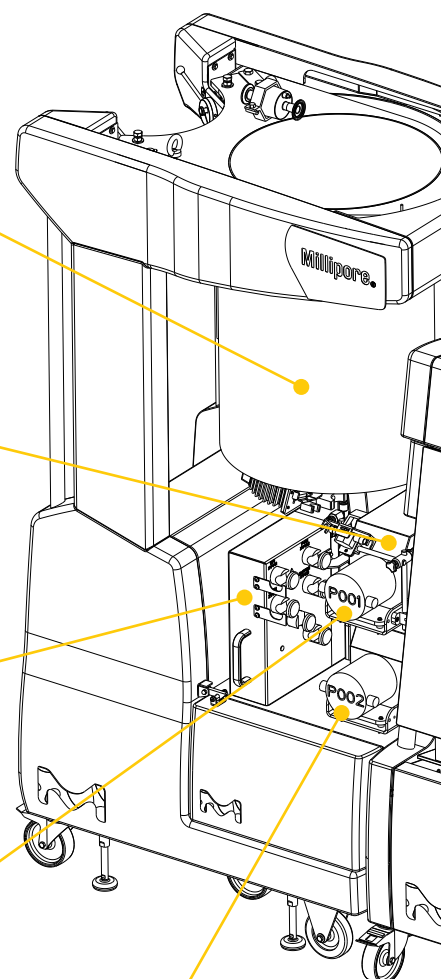

Configure Your TFF system to Meet Your Process Needs

Smart Cart

The smart cart is a piece of equipment, allowing to install the TF2S clamshell, to easily switch between scales. The smart cart includes the HMI displaying the CCP® software for fully automated processing.

Select the right clamshell size for your process between the TF2S, up to 20 L/min.

Feed/Recycle Tank Cart

Choose a polyethylene tank or a stainless-steel jacketed tank with temperature control (50, 100, or 200 L).

Pump Cart

The pump cart includes the feed and transfer pumps, along with the inlet manifold. Size available: TF2S up to 20 L/min. To perform TFF in closed mode, a specific pump cart with six additional valves is available (for TF2S size only) to be used in conjunction with our Smart Flexware® assemblies kit, which has been designed to enable closed processing.

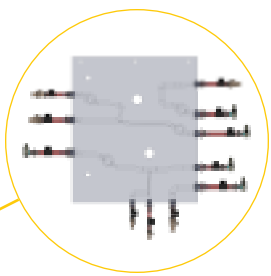
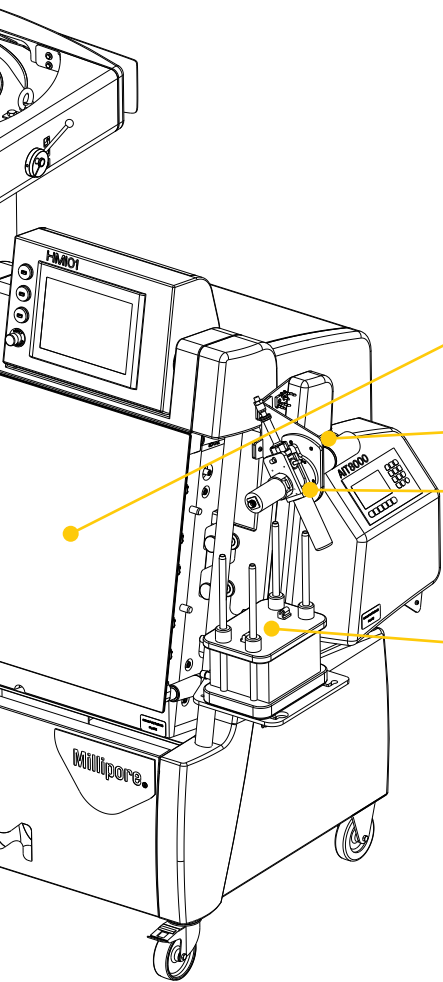

Flexware® Assembly
with CPC® MPC and
TC connectors

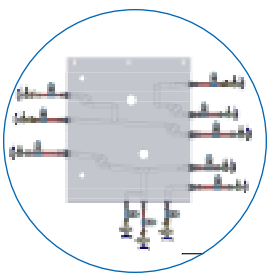

Flexware® Assembly
with CPC® AseptiQuik®
connectors, enabling
closed processing

Sampling support for closed
flowpath assemblies using
**NovaSeptum® sterile
sampling system**

**Permeate single-use
sensor flow cell**

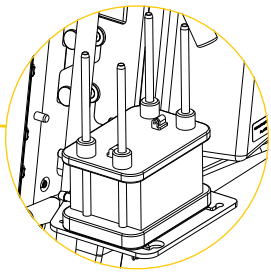

Pellicon® 2 and 3 cassette
are ideal for high titer
therapeutic antibodies, as
well as demanding filtration
processes that require
high operating pressures,
temperatures, and caustic
cleaning regimes

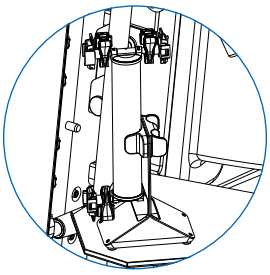

The use of single-use
Pellicon® capsule,
together with the
flowpath designed to
enable closed processing,
allows to further reduce
contamination risk and
remove the need to connect
and disconnect lines during
TFF operation

Common Control Platform® (CCP®) Software

Our CCP® automation software allows central control of all pumps and valves on the smart cart and any connected carts. The software is designed for cGMP facilities, developed in line with GAMP® 5 recommendations for automation software, and fulfills FDA guideline 21 CFR Part 11 requirements for electronic records and signatures.

Instrumentation

Conductivity, UV, and pH can be monitored on the filtrate line with single-use, or multi-use sensors.

A non-intrusive flowmeter can also be installed on the filtrate line for accurate inline flow measurement.

Filter or Holder Support

Based on your configuration, you can select between the Pellicon® cassette holder, for compressed devices, or a support plate, to install the different sizes of Pellicon® capsules.

Sampling Support

Sampling solutions can be included in all Smart Flexware® assemblies on filtrate and retentate line, with the associated support hardware.

The Smart Fleware® assembly designed to enable closed processing automatically includes NovaSeptum® sterile sampling solution on the retentate and filtrate line. Specific hardware has been designed to support these sterile sampling solutions.

Specifications

General TFF Specifications

Pressure Rating	Up to 4 bar (58 psi) Environmental Temperature
Range	2–30 °C Process Connection
Type	Colder CPC® and TC connections and CPC® AseptiQuick® connectors for closed enabled flowpath
Humidity	10–90% (non-condensing)
Utility Requirements	<p>Compressed air: 6 bar minimum (oil-free). Maximum consumption: 4 L/min</p> <p>Power supply</p> <p>Smart Cart: 220–240 VAC, 50/60 Hz, 1 phase or 100–120 VAC, 50/60 Hz, 1 phase, maximum consumption: 1KW</p> <p>Tank Cart: 220-240 VAC, 50-60 Hz, 1 phase, maximum consumption: 0.1kW for 50L, 0.4kW for 100/200L</p> <p>Pump Cart</p>
Wetted Materials	<p>Electrical cable with CN, EU, JP, NA or UK plugs delivered with the system</p> <p>PureFlex® film, Platinum cured silicone o-ring and tubing, PE fittings and Inline Sampler, Polysulfone flow cell (SUC) and TFF cassette/ Liner, PP TC connections, Polysulfone and polycarbonate connections, SS316 L (flow meters and conductivity pins on SUC), PP pump body, Santoprene® pump diaphragms, EPDM pump non-return valve, quartz UV cell windows, USP <88> Class VI, Animal Free or EMA/410/01 compliant.</p>
Electrical Compliance	CE (2006/95, 2004/108, 2006/42/EEC)

TFF Specifications

TF2S standard and closed processing	
Membrane Holder Capacity	0.5–5.0 m ²
Feed Flow Rate	2.0–20.0 L/min
Feed Flow Measurement	Flow is calculated to an accuracy of +/- 10% MV with a minimum pressure of 1 bar on the feed line
Filtrate Flow Measurement	Flow can be calculated to an accuracy of +/- 5% MV (between 0.5–8.0 L/min) using the optional external 0–600 kg floor weight scale. RC Flow can be measured using an optional non-intrusive flowmeter to an accuracy of +/- 5% MV above 2 L/min, +/- 0.12 below 2 L/min.
Process Fluid Temperature Range	2–45 °C
Inlets	5 inlets (air plus 4 fluids)
Outlet Ports	1 drain, 1 recovery, 1 filtrate
Pipe Work Inside Diameter	TF2S 3/4 in. (Inlet Manifold), 5/8 in. (recirculation loop), 1/2 in. (Filtrate & Diafiltration lines), 3/8 in. (Product Recovery & Drains) i.d.
Tank Size	50 L, 100 L, 200 L
Minimum Working Volume (Excluding cassette's feed volume, and function of recirculation flow rate)	Down to 0.7 L
Hold-up Volume	<700 mL (exc filtration device)
Unrecoverable Volume	Virtually zero using a displacement by buffer
Dimensions	Height: 202 cm Width: 217 cm (224 cm for closed processing systems) Depth: 101 cm
Uncrated Weight	~ 1000 kg — depends on configuration

TFF Sensor Performance

Sensor Type	Range	Accuracy
Pressure Sensors	0–4 bar	+/- 0.2 bar
Optional Filtrate Conductivity	0–150 µS/cm Default range: 0–100 µS/cm	+/-3% MV + 0,4µS/cm
Tank Temperature	2–45 °C	+/- 2 °C
Optional Filtrate UV	0–2 AU (wavelengths 280/300 nm)	+/- 2% FS
Tank Weight	0–50 kg; 0–100 kg 0–200 kg	+/- 0.3% FS
Optional Flow Meter	Non-contact >2.0 L/min 0.4 to 2.0 L/min	+/- 5% MV at 20 °C +/- 0.12 L/min

Tangential Flow Filtration System Performance

The Mobius® FlexReady Solution with Smart Flexware® assemblies for TFF performance is documented in the system performance guide. Some examples of key performance data are highlighted below. The system includes several unique design features that make it suited for demanding final concentration and buffer exchange applications, where the ability to accommodate elevated protein viscosity, low final volume and high purity requirements is key to process success. Feed pump capability and line pressure drop were tested with solutions up to 35 cP (configuration with CPC® MPC/MPX and TC connectors) and up to 50 cP (configuration with CPC® AseptiQuik® connectors), giving you confidence in your operation as protein concentration increases. The recycle container and flow path were designed to enable recirculation at process flow rates with a minimum product volume, while maintaining adequate mixing and avoiding vortexing or air entrainment.

The Smart Flexware® assembly includes innovative valving where the transfer and product recovery lines intersect with the recirculation flow path. By replicating the functionality of traditional stainless steel zero-static valves, dead-legs are eliminated in the critical product path to maintain product purity and enable highly effective buffer exchange for demanding final UF/DF operations (**Figure 3**).

At the end of concentration and diafiltration operations, achieving maximum recovery of product from the system is essential for process success. A straightforward sequence of steps has been developed to maximize product yield during recovery. The method can be carried out using either air or buffer to displace product from the flow path lines and membrane channels (**Figure 4**). This provides flexibility for users to select a product recovery strategy that is most in line with their specific process objectives, knowing that either choice will result in success.

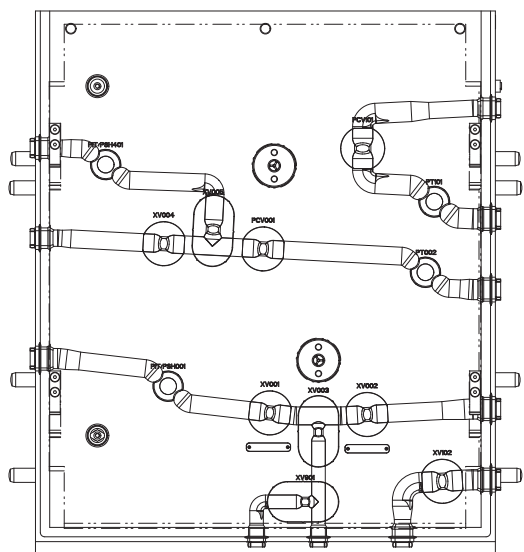

Figure 3: Innovative flow path provides zero-dead-leg valving for excellent buffer exchange and purity.

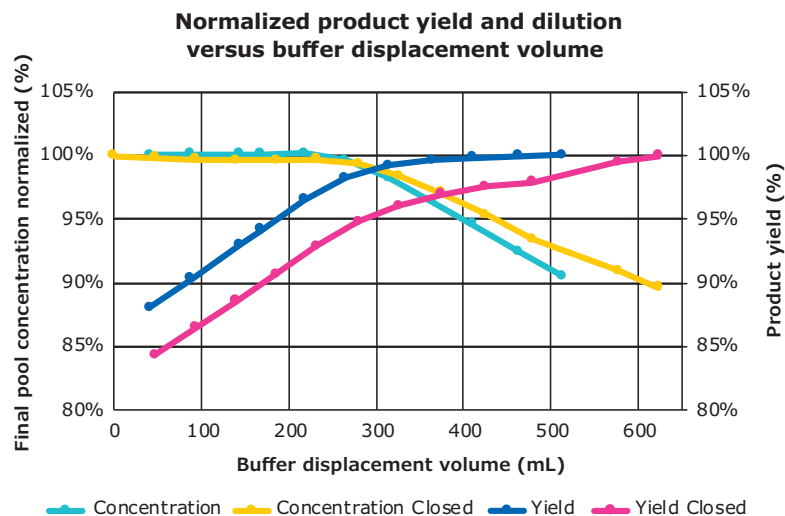

Figure 4. Product dilution during recovery with buffer can be minimized while achieving high product yield.

Related Products

Pellicon® Cassettes

These advanced, high-performance cassettes are ideal for high titer therapeutic antibodies, as well as the more demanding filtration processes that require higher operating pressures, temperatures, and caustic cleaning regimes.

Pellicon® Capsules

Our innovative TFF capsules are ideal for processing biopharmaceuticals that require single-use capabilities, including enhanced ease-of-use, process flexibility, rapid product turnaround, and reduced operator exposure.

First-of-its-kind, the capsule has a holderless, self-contained design for fast and flexible product changeover. Provided gamma sterilized and available with aseptic connectors, the capsule is ready to use in a closed process within minutes.

TFF Devices Holder & Support

The TFF system can be used with a Pellicon® cassette holder or a Pellicon® Capsule support plate. The cassette holder enables use of single-use liner plates to isolate the process fluid from the holder endplates in order to achieve robust membrane compression, while eliminating cleaning and validation efforts. The support plate accommodates the Pellicon® Capsule stand for devices as well as self-standing Pellicon® Capsule manifolds for fast and easy setup in a closed process.

Pellicon® 3 Cassette



Pellicon® Capsule and Pellicon® Capsule Manifold



Pellicon® Capsule Stand

Services

To help you navigate the highly regulated and complex pharmaceutical and biotechnology industries, we offer a wide range of collaborative, comprehensive support services to meet your unique manufacturing and regulatory requirements. We provide you with support through all stages, from the system installation and qualification, to the training and maintenance needed to keep your equipment running smoothly and efficiently - for accurate and reproducible performance day after day. All services are performed by our global experts who have unique intimate knowledge of our equipment, backed by years of experience.

Installation and Qualification

Our qualification services are designed to make the integration of our system into your process as seamless as possible. We ensure your equipment is properly installed and functioning per your pre-defined requirements.

- Factory acceptance test (FAT)
- Installation qualification/operational qualification (IQ/OQ)
- Performance Qualification (PQ) Support
- Full test package: this service is an alternative to standard IQ/OQ

Trainings

Operator Training

Designed for pharmaceutical, biotechnology, and medical device manufacturing personnel who operate downstream processing equipment, our interactive course provides an overview of the Mobius® FlexReady TFF system with Smart Flexware® assemblies. Installation of Smart Flexware® assemblies and CCP® software are also described and practiced in hands-on sessions. To meet cGMP requirements, course graduates will receive a certificate upon completion.

After training with our technical experts, operators will be prepared to operate and manage your Mobius® FlexReady TFF system with greater confidence. This is especially important if your company experiences rapid ramp-up or high operator turnover.

Common Control Platform® (CCP®) Software Training

If your system is used in process development or supports many different molecules and needs to rapidly adapt your system to new process characteristics, our biomanufacturing engineers can also provide you with a specific training, including a hands-on session so you can create and manage your own recipes and system.

System Service Reliance Plans

To ensure optimum equipment uptime and regulatory compliance while mitigating risks, we have developed System Service Reliance Plans; a complete range of services for your systems and equipment. These comprehensive service and support packages allow you to select a coverage level that best fits your needs.

- **Essential Reliance Plan:** includes a selection of preventive maintenance and troubleshooting services
- **Advanced Reliance Plan:** provides higher coverage, with faster response time and priority access to remote and on-site support
- **Total Reliance Plan:** guarantees the highest level of protection for your equipment and our fastest reaction time

For additional details, please refer to the System Service Reliance Plans data sheet (MS_DS7881EN), available at [SigmaAldrich.com/services-plans](https://www.sigmaaldrich.com/services-plans)

Specialized Support

CCP® Software Recipe Design

Every process is unique and, to ensure that your system is optimized to deliver the best performance, our biomanufacturing engineers will configure CCP® software recipes for your specific process. This allows your system to run fully automatically, resulting in consistency and reduced operator error.

Spare parts

Purchasing spare parts directly from us is the only way we can guarantee that you get the right parts every time, with the same level of performance as the original.

For details and ordering information, please check the illustrated spare parts list (**MS_CA7934EN**), available at SigmaAldrich.com/TFF-systems

MilliporeSigma
400 Summit Drive
Burlington, MA 01803

For more information, please visit
SigmaAldrich.com/TFF-systems

To place an order or receive technical assistance, visit
EMDMillipore.com/contactPS

